

Bristol-Myers Squibb Corporation via participation in a State of Connecticut Cooperative High Technology Research and Development Grant (P.H.B. and D.L.B.). J.M.W. is a recipient of a Traineeship in Molecular Biophysics via NIH 1T32 GM-08271 (P.H.B. and D.L.B.). Computer time on the CRAY YMP was provided by the Pittsburgh Supercomputer Center. The assistance of Dr. G. Ravishanker and Mr. F. DiCapua in preparing figures

is gratefully appreciated. We thank Ms. J. Srinivasan for providing NMR data for initial analysis.

Supplementary Material Available: Tables of all distance, β , and θ information used in the calculation of NMR parameters (24 pages). Ordering information is given on any current masthead page.

Communications to the Editor

Determination of Interchain NOEs in Symmetrical Dimer Peptides

Miquel Pons* and Ernest Giralt

Department of Organic Chemistry, University of Barcelona
Martí i Franquès, 1-11, E-08028 Barcelona, Spain

Received October 10, 1990

A considerable number of peptides and proteins are found in nature as dimers linked by disulfide bridges¹⁻⁴ or noncovalent interactions.^{5,6} In these cases, there are ambiguities in the assignment of NOE interactions as two protons that show a NOE contact can belong to the same unit or to symmetry-related units. These two interpretations will lead, in general, to completely different conclusions about the structure of the molecule.⁷ One particular case occurs when the two protons involved belong, in the intrachain case, to the same spin system, as the NH and CH_α protons in the same residue. In this communication we describe the use of a semiselective TOCSY–NOESY experiment to differentiate between these two types of interaction.

Differentiation between intra- and interchain interactions demands the use of mixed dimers⁸ in which the two chains differ, for example, by the substitution of deuterium for one or several of the protons involved, the aim being to *selectively* suppress one of the two types of interaction. Unambiguous results can only be obtained when both NOE-related protons are replaced by deuterium, either in the same (Figure 1b) or in different chains (Figure 1c). The substitution of deuterium for only one proton leads to the same degree of suppression of intra- and interchain NOEs (Figure 1d) and therefore, by itself, cannot differentiate between the two situations.

Deuteration of only one of the protons can still be used unambiguously, provided a through-bond connectivity can be established between the two points prior to the NOESY experiment (Figure 1e). In the TOCSY–NOESY⁹ experiment coherence is transferred first through scalar coupling and then through dipolar coupling, and therefore this experiment can be conveniently used to distinguish NOEs between protons with a spin system from those between protons belonging to a symmetry-related, different

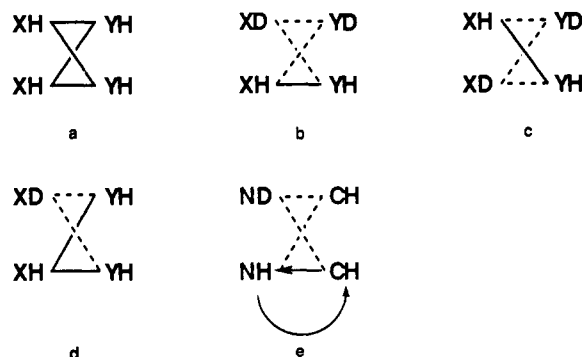

Figure 1. Intra- versus interresidue interactions in a fully protonated sample (a) or in mixed dimers (b–e). Dimers b and c are doubly labeled, and d and e are singly labeled. Full lines represent cross-relaxation pathways leading to the appearance of an NOE, and dashed lines represent suppressed pathways. In e the curved arrow represents magnetization transfer through scalar coupling and therefore implies that the two protons belong to the same spin system. The NOE has also been represented by an arrow to indicate the intrinsic asymmetry of the selective TOCSY–NOESY experiment.

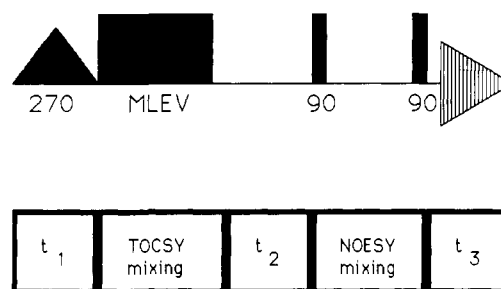

Figure 2. The semiselective TOCSY–NOESY experiment. Semiselective excitation is obtained by a self-refocusing 270° Gaussian pulse.¹¹ The phases of this pulse and the two 90° hard pulses were cycled as in a conventional NOESY experiment. The phases of the pulses in the MLEV sequence were kept constant. Spectra were recorded in the absolute value mode.

spin system using single-labeled mixed dimers.

We use a version of the selective TOCSY–NOESY experiment¹⁰ in which the preparation pulse is a 270° Gaussian pulse¹¹ that excites the complete amide region (Figure 2). A sample of a dimer peptide containing mixed dimers in which only one in each pair of symmetry-related NH protons has been replaced by deuterium can be conveniently obtained by partial exchange with D₂O.

Magnetization derived from the nonexchanged NH protons is spread within the spin system by the MLEV mixing.¹² During the NOESY part of the sequence, magnetization can be trans-

(1) Kangawa, K.; Matsuo, H. *Biochem. Biophys. Res. Commun.* **1984**, *118*, 131–139.

(2) Proux, J. P.; Miller, C. A.; Li, J. P.; Carney, R. L.; Girardie, A.; Delaage, M.; Schooley, D. A. *Biochem. Biophys. Res. Commun.* **1987**, *149*, 180–186.

(3) Tancredi, T.; Temussi, P. A.; Beato, M. *Eur. J. Biochem.* **1982**, *122*, 101–104.

(4) Morize, I.; Surcouf, E.; Vaney, M. C.; Epelboin, Y.; Buehner, M.; Fridlanski, F.; Milgrom, E.; Mornon, J. P. *J. Mol. Biol.* **1987**, *194*, 725–739.

(5) Breg, J. N.; Boelens, R.; George, A. V. E.; Kaptein, R. *Biochemistry* **1989**, *28*, 9826–9833.

(6) Zagorski, M. G.; Bowie, J. U.; Vershon, A. K.; Sauer, R. T.; Patel, D. *Biochemistry* **1989**, *28*, 9813–9825.

(7) Breg, J. N.; Opheusden, J. H. J.; Burgering, M. J. M.; Boelens, R.; Kaptein, R. *Nature* **1990**, *346*, 586–589.

(8) Arrowsmith, C. H.; Pachter, R.; Altman, R. B.; Iyer, S. B.; Jardetzky, O. *Biochemistry* **1990**, *29*, 6332–6341.

(9) Griesinger, C.; Sorensen, O. W.; Ernst, R. R. *J. Magn. Reson.* **1989**, *84*, 14–63.

(10) Sklenár, V.; Feigon, J. *J. Am. Chem. Soc.* **1990**, *112*, 5644–5645.

(11) Emsley, L.; Bodenhausen, G. *J. Magn. Reson.* **1989**, *82*, 211–221.

(12) Levitt, M. H.; Freeman, R. *J. Magn. Reson.* **1981**, *43*, 502–507.

Table I. Normalized Cross-Peak Intensities in a Selective TOCSY-NOESY Experiment

peptide	pathway: ^a sample: ^b	(¹ NH- ¹³ CH)> ¹ NH		(¹ NH- ¹³ CH)> ¹⁵ NH		¹⁵ NH> ¹³ CH	
		A	B	A	B	A	B
¹ Gly				6.1 ^c	3.8 ^c	11.1 ^c	12.9 ^c
² Cys		2.4	2.5	5.0	3.7	35.4	41.3
³ Phe		2.9	3.8	12.2	10.4	21.7	25.5
⁴ Val		8.1	6.8				
⁵ Pro						32.4	36.7
⁶ Cys		4.4	5.6	14.6	8.6	7.8	7.8
⁷ Gly		3.7	3.9				

^a Magnetization transfer pathways are represented as follows: The leftmost NH corresponds to the selectively excited proton. TOCSY mixing occurs between the protons enclosed in parentheses, and the > sign represents NOE transfer in the direction indicated. The cross peak ($a > b$) appears at frequencies $\omega_1 = a$, $\omega_2 = b$. ^b Sample A: 64 mg of peptide was dissolved in 0.7 mL of d_6 -DMSO. Sample B was obtained from A by partial exchange with D₂O. Degree of deuteration: 31%. Spectra were obtained in a Varian VXR-500 instrument with a 10-dB fixed attenuator at the output of the transmitter. The 270° Gaussian pulse was 2 ms and the 90° pulse width was 17 μ s. TOCSY mixing: 30 ms (6.5 kHz). NOESY mixing: 300 ms. ^c Normalized to the ¹⁵NH intensity. Otherwise, normalized with respect to ¹NH intensity. Units are percent of the intensity of the reference peak. Intensities are the average of two experiments with the same samples. Reproducibility is better than 10%.

ferred back to the original NH in the same residue (intraresidue NOE) or to the symmetry-related NH proton (interresidue NOE). The latter interaction is suppressed because in the mixed dimers only one of the symmetry-related amide protons has been exchanged.

If x is the probability of one particular site to be deuterated, i.e., the degree of deuteration of the sample, the intensity of a purely interresidue cross peak in a semiselective TOCSY-NOESY experiment will be approximated by

$$I = I_0(1 - x)^2$$

where I_0 is the intensity of the cross peak in the fully protonated sample. The intensity of a purely intraresidue cross peak will be given simply by

$$I = I_0(1 - x)$$

which is the same dependency expected for the diagonal peaks. It follows that for purely intraresidue interactions the intensity ratio between cross and diagonal peaks will be independent of the degree of deuteration.¹³

The sequence has been tested by using the synthetic peptide dimer

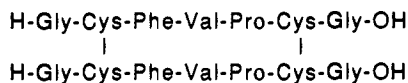

with two disulfide bridges that ensure a parallel orientation of the two chains.¹⁴ The results are summarized in Table I. The cross peaks between CH _{α} in one sequence position and NH in a different one (columns 4 and 5) are attenuated by partial deuteration independently of whether the two residues belong to the same or a different chain. The last two columns in Table I (columns 6 and 7) show the normalized intensities of the cross peaks located on the opposite side of the diagonal. They arise from NOE transfer between NH protons which have been directly excited and neighbor CH _{α} protons as in an ordinary NOESY experiment, and as expected, they are not attenuated by deuteration. On the other hand, it can be seen that the normalized intensity of the cross peaks between CH _{α} protons, which have been prepared by TOCSY transfer from the selectively excited NH's and NH protons assigned to the same sequence position (columns 2 and 3) is independent of the degree of deuteration in all cases except for ⁴Val. The decrease in intensity of the CH _{α} NH cross peak of this residue indicates that it contains a contribution from the interchain interaction between the two symmetry-related valine residues. This long-range interaction would have been overlooked in an ordinary NOESY experiment.

The selective TOCSY-NOESY experiment is a pseudo-3D NMR experiment. In a complete 3D experiment differentiation

between intra- and interresidue CH _{α} NH NOEs would be obtained from the intensities of the back-transfer peaks as a function of the degree of deuteration.

Acknowledgment. We thank Dr. M. Ruiz-Gayo and Miss M. Royo for the peptide sample and Dr. M. Feliz and Dr. F. Albericio for helpful discussions. This work was partially supported by funds from the CICYT (PB90-257).

Registry No. GCFVPCG peptide dimer, 118972-74-0; GCFVPCG peptide dimer (deuterated), 133833-57-5.

Type I and II Copper Sites Obtained by External Addition of Ligands to a His117Gly Azurin Mutant

Tanneke den Blaauwen, Mart van de Kamp, and Gerard W. Canters*

Gorlaeus Laboratories, Leiden University
Leiden, The Netherlands

Received February 8, 1991

Low molecular weight copper complexes are often used as model compounds to study the coordination of Cu ions in proteins. Usually this approach meets with only partial success. Here a new strategy is reported by which a Cu site is made accessible in situ to different ligands by site-directed mutagenesis.

There has been much speculation recently on the mode of action of type I copper proteins,¹⁻⁷ in particular on the pathways followed by the electrons on their way to and from the active site inside the protein. A study of azurin mutants has recently provided strong support for the idea that in the electron self-exchange reaction as well as in the reaction of azurin with its presumed physiological partners (cytochrome *c*₅₅₁ and nitrite reductase) His117 is the port of entry and exit for electrons.^{5,6} The (unrefined) crystal structure of wild-type (WT) *Pseudomonas aeruginosa* azurin (reported at 2.7 Å⁸) and the refined structures of two His35 mutants (reported at 1.9-Å and 2.1-Å resolution⁹) show

* Address for correspondence: G. W. Canters, Gorlaeus Laboratories, PO Box 9502, 2300 RA Leiden, The Netherlands.

- (1) Farver, O.; Blatt, Y.; Pecht, I. *Biochemistry* 1982, 21, 3556-3561.
- (2) Farver, O.; Pecht, I. *Isr. J. Chem.* 1981, 21, 13-17.
- (3) Silvestrini, M. C.; Brunori, M.; Wilson, M. T.; Darley-Usmar, V. M. *J. Inorg. Biochem.* 1981, 14, 327-338.
- (4) Adman, E. T. in *Metalloproteins*; Harrison, P., Ed.; Verlag Chemie GmbH: Weinheim, 1985; Part 1, pp 1-41.
- (5) van de Kamp, M.; Floris, R.; Hali, F. C.; Canters, G. W. *J. Am. Chem. Soc.* 1990, 112, 907-908.
- (6) van de Kamp, M.; Silvestrini, M. C.; Brunori, M.; van Beeumen, J.; Hali, F. C.; Canters, G. W. *Eur. J. Biochem.* 1990, 194, 109-118.
- (7) Groeneveld, C. M.; Canters, G. W. *J. Biol. Chem.* 1988, 263, 167-173.
- (8) Adman, E. T.; Jensen, L. H. *Isr. J. Chem.* 1981, 21, 8-12.
- (9) Nar, H.; Messerschmidt, A.; Huber, R.; van de Kamp, M.; Canters, G. W. *J. Mol. Biol.* 1991, 218, 427-447.

(13) It should be stated that these intensity relationships are only an approximation to the true values as the presence of deuterons in the molecule is expected to affect the different cross-relaxation rates.

(14) Ruiz-Gayo, M.; Albericio, F.; Pons, M.; Royo, M.; Pedrosa, E.; Giralt, E. *Tetrahedron Lett.* 1988, 29, 3845-3848.